

Operating Principles

When the Solinst Bladder Pump is placed in a well or borehole, water rises inside the bladder and sample tubing to static level. Compressed nitrogen or air is supplied to the pump via the drive tubing using a Control Unit. Applying pressure causes the bladder to compress and closes the bottom check valve, forcing water from the bladder into the sample tubing.

During a vent cycle the pressure is released from the drive tubing. The bladder returns to its initial state as water re-enters the pump, while the top check valve prevents water already in the sample tubing from falling back into the bladder. Cycling the drive and vent provides water flow, the rate of which can be adjusted for purging or sampling.

Pump Operation

Portable: The pump will be attached to skip-bonded, dual 1/4" OD tubing, mounted on a reel.

- To accommodate the 1/4" sample tubing, insert the 1/4" compression adaptor into the 3/8" sample line fitting. The 3/8" fitting nut may have to be loosened first, then tightened after the 1/4" adaptor is inserted (see overleaf).
- Push the tubing inserts into the tubing and into the drive and sample compression fittings of the Bladder Pump. The compression fitting nuts may have to be loosened before the tubing is inserted. Tighten the nut 1-1/4 turns past finger tight for a proper seal (see overleaf).
- Lower the assembled Bladder Pump into the well, using a stainless steel safety line connected to the eye bolt on the pump. The Solinst Model 103 Tag Line can be used for this purpose.
- Connect the supply line with the in-line dryer from the compressed gas source to the Control Unit. The drive line connects from the Control Unit to the reel (drive and supply lines come with the Model 464 Control Unit).
- Attach a short (3 ft. or 1 m) length of 1/4" OD sample line to the sample connector on the reel.

Dedicated: The pump will come with a roll(s) of tubing to be cut to length, as required, for attachment to a Wellhead.

- Cut the tubing to desired length. See step b) above for tubing connection instructions to the pump.
- Attach the sample line and drive line to the appropriate push fitting on the underside of the Wellhead (see diagram at right for use of push fittings and adaptors).
- Lower the Bladder Pump into the well, using a stainless steel safety line if desired. If useful, attach the safety line to the suspension hook on the underside of the Wellhead. Push the Wellhead down firmly onto the riser casing.
- Connect the supply line with the in-line dryer from the compressed gas source to the Control Unit. The drive line connects from the Control Unit to the Wellhead (drive and supply lines come with the Model 464 Control Unit).
- Attach a short (3 ft. or 1 m) length of 3/8" OD sample line to the sample connector on the Wellhead (see diagram at right for use of push fitting).

For detailed pumping instructions, please see the Solinst Model 464 Control Unit Operating Instructions.

- Notes:**
- The maximum depth for stainless steel Bladder Pump operation is 500 ft. (150 m) below grade.
 - DO NOT** exceed an operating pressure of 250 psi.
 - The pump has been decontaminated before leaving Solinst, however, you may wish to decontaminate your pump before use. The pump should be decontaminated between wells.
 - Tube fittings are based on use of 1/4" drive line and 3/8" sample line. A 3/8" to 1/4" adaptor is also supplied, if dual 1/4" tubing is preferred, or when using a portable reel.

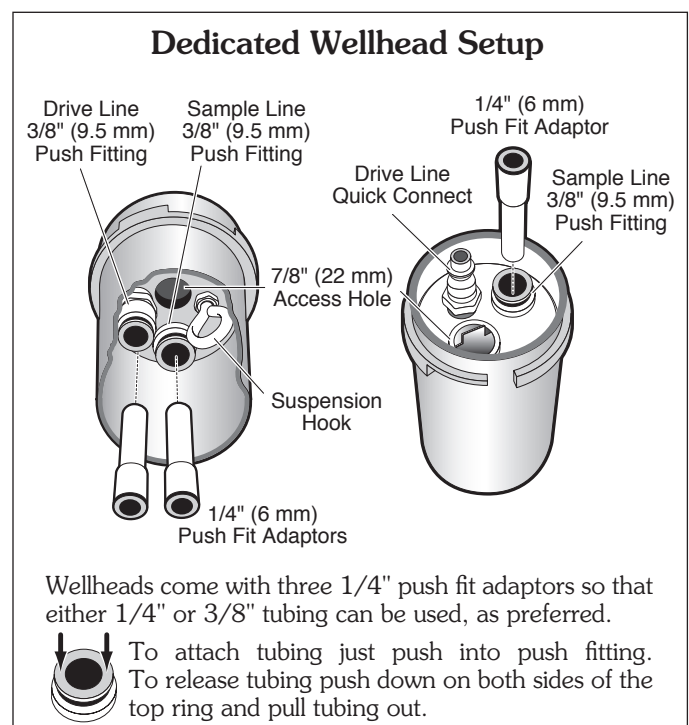
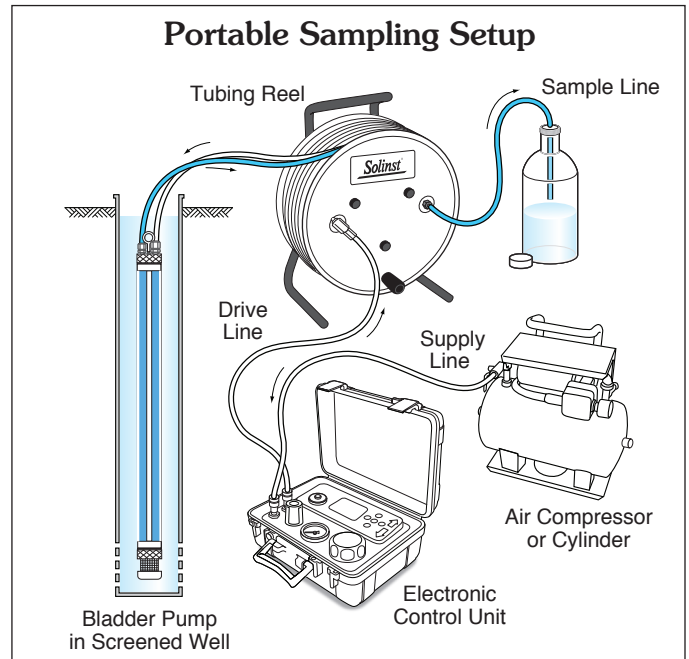

Disassembly

1. Unscrew and Remove the Filter Retainer, Filter Screen and Top and Bottom Platens, being careful not to lose the Check Balls. Remove the Pump Body.
2. Remove the Top and Bottom Retainers, then remove the Centre Rod from the Bladder Sleeve by pushing one end of the Centre Rod onto a solid surface, while gripping the Bladder Sleeve. It may be necessary to use one of the Retainers to push the Centre Rod out.
3. Remove the Bladder from the Bladder Sleeve using a pair of needle nose pliers.

Decontamination

Notes: 1. Always follow your local guidelines and standard protocols.
2. Do not use acetone on the O-rings.

1. Completely disassemble the Pump.
2. Wash all pump components with phosphate-free soap or a detergent.
3. Rinse all components thoroughly with deionized water.
4. Replace any worn O-rings and Bladder if necessary, and reassemble.

Reassembly

1. Manually slide the new Bladder into the Bladder Sleeve. It should extend about 1/4" beyond the Bladder Sleeve at both ends.
2. Using your finger, slightly flare both ends of the Bladder.
3. If necessary install new O-rings on both Top and Bottom Retainers and both Platens. (Total of 8.)
4. Hold both ends of the Replacement Bladder to minimize slip within the Sleeve. Liberally lubricate a Retainer with water, and insert it first at a 45° angle and rotate gently back and forth until the Bladder has been pushed about 1/4" past the second O-ring on the Retainer.
5. Insert the Centre Rod into the Sleeve until it rests in the Retainer.
6. Lubricate the second Retainer with water, align it onto the Centre Rod and working gently to avoid twisting or crumpling of the Bladder, push the Retainer into the Bladder until it is about 1/4" past the second O-ring.
7. Take the Bottom Platen and drop the 3/8" OD Teflon Check Ball into it. Do not force the ball in as the correct ball should drop in easily.
8. Fit the Bottom Retainer of the assembly firmly into the Bottom Platen.
9. Slip the Pump Body over the assembly and screw it onto the Bottom Platen. If tight, use a single wrap of Teflon Tape.
10. Drop a 3/8" OD Teflon Check Ball into the Top Platen and screw the Pump Body onto it.
11. Shake the assembled pump to hear if the Check Balls rattle. If not, repeat steps 8 to 10 to ensure that the Check Balls are positioned correctly.
12. Fit the Filter Screen onto the Bottom Platen and screw the Filter Retainer into place.

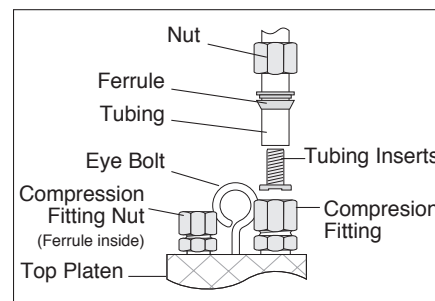
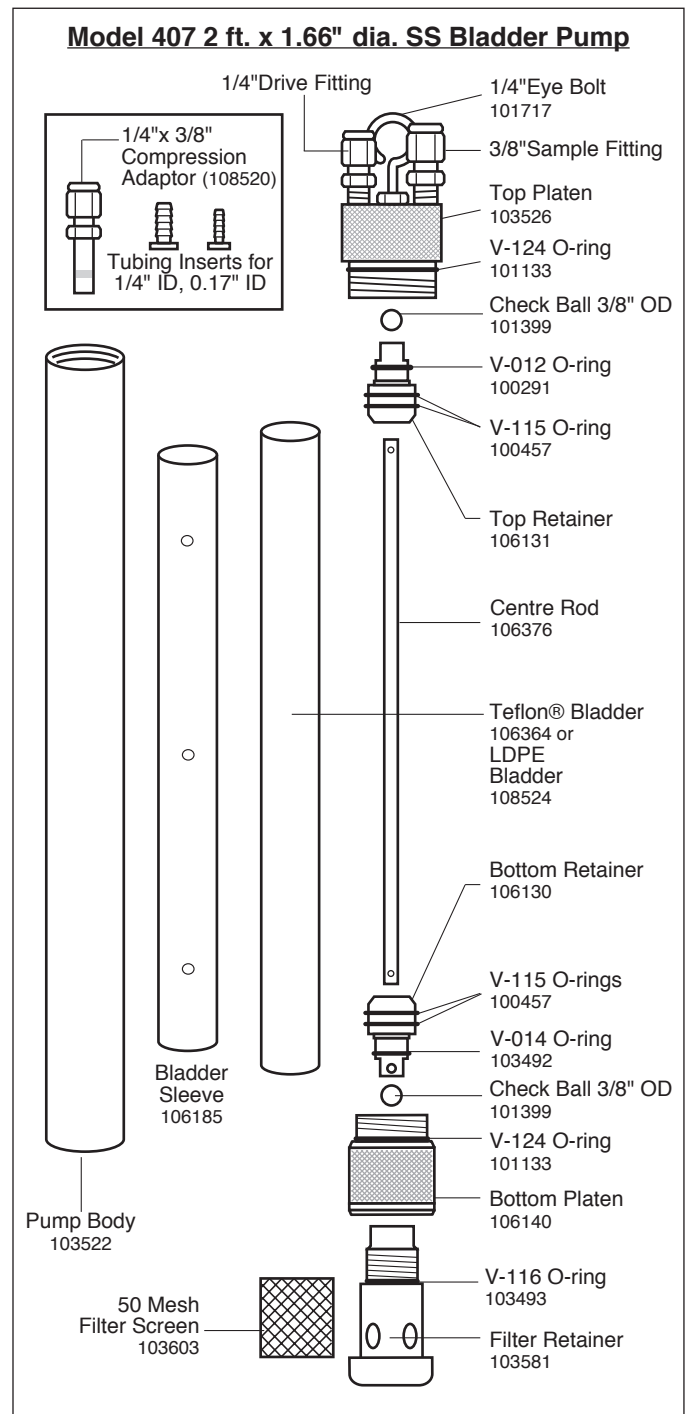

Note:

Be careful not to lose the two pieces of the ferrule if loosening or removing the nut from the compression fitting.



TTT Environmental
Instruments and Supplies

*The preferred source for instrument
Rentals, Sales, Service and Supplies!*

4201 B Street
Anchorage, AK 99503
(907) 770-9041

25420 74th Avenue S.
Kent, WA 98032
(253) 373-9041

la Ltd.
61-2023

Solinst®